

**A ELEVATION**  
SCALE: 3/4"=1'-0"

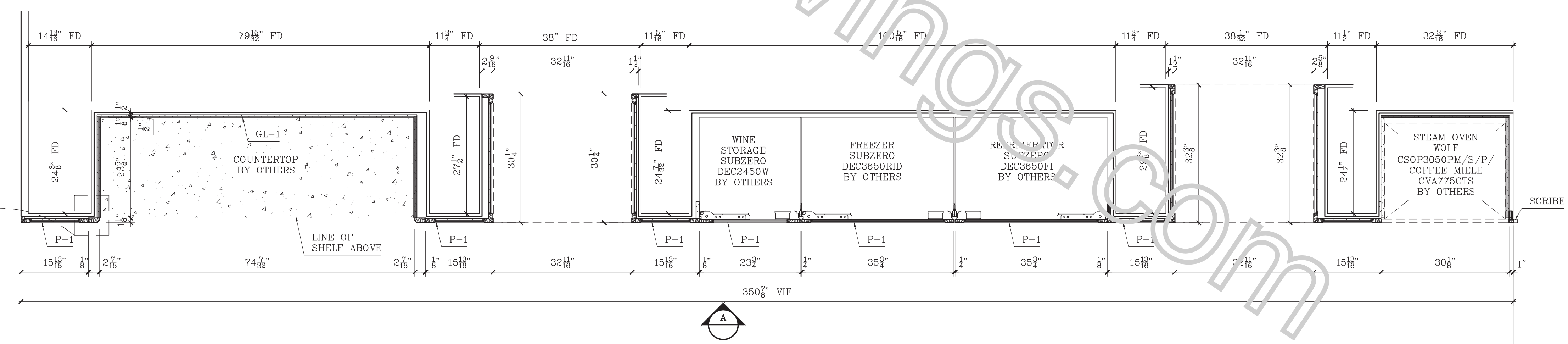

**PLAN VIEW OF KITCHEN 116 - REFRIGERATOR/FREEZER WALL**  
SCALE: 3/4"=1'-0"

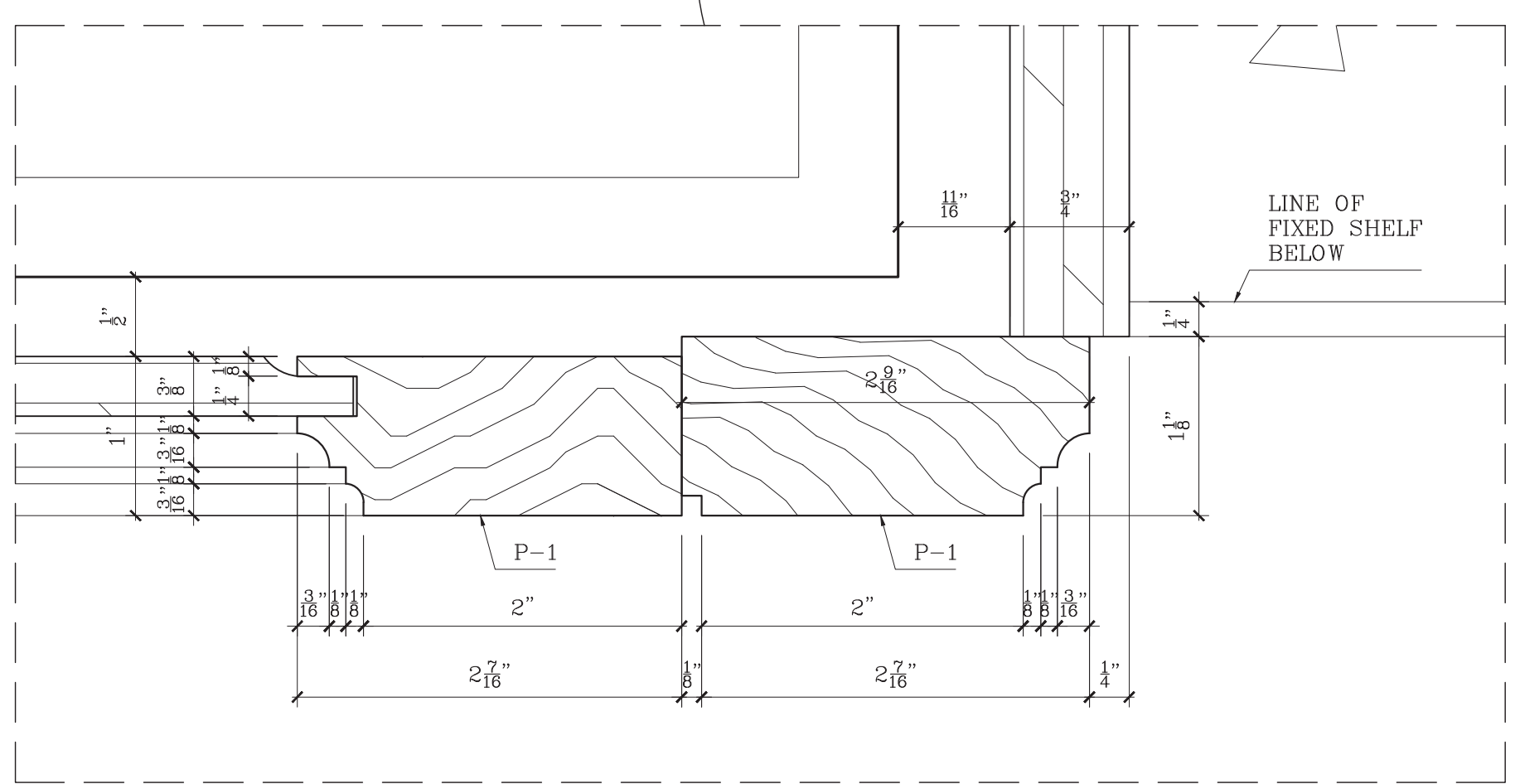

**SPECIFICATIONS**

**FINISHES**

<b>P-1</b>	RIFT SAWN WHITE OAK, STAINED & CLEAR
<b>CM</b>	CLEAR MAPLE INTERIOR
<b>GL-1</b>	GLASS, TBD

**HARDWARE**

<b>H-1</b>	EURO HINGE - BLUM, SOFT CLOSE, CONCEALED
<b>H-2</b>	SHELF PINS
<b>H-3</b>	PULL, TBD
<b>H-4</b>	A&M C-FLAT 18
<b>H-5</b>	Z-CLIPS
<b>H-6</b>	DRAWER SLIDE, SOFT CLOSE - BLUM, MOVENTO

**APPLIANCE & EXCLUSIONS**

COUNTERTOPS & BACKSPLASH BY OTHERS
APPLIANCES BY OTHERS

APPROVED/NO CHANGES  
APPROVED/AS NOTED  
REVISE AS NOTED/RESUBMIT

SIGNATURE \_\_\_\_\_ DATE \_\_\_\_\_

**LEGEND**

	-ELEVATION No		-CABINET No		-FIELD JOINT
	-DRAWING No		-NOTES		-SHOP JOINT
	-ITEM No		-SPECIFICATIONS		

**REVISIONS**

Nr	DATE	DESCRIPTION	BY	OBS.

**ABBREVIATIONS**

AFF=Above Fin Floor	FE=Finished End
BSE=Base	FF=Face Frame
BCK=Back	FO=Finished Opening
CAB=Cabinet	FP=Fixed Panel
CAS=Case	ID=Inner Dimension
CL=Clear Opening	OD=Outer Dimension
CTOP=Counter Top	PNL=Panel
DB=Drawer Box	RO=Rough Opening
DF=Drawer Face	POT=Pull Out Tray
FD=Field Dimension	REM=Removable Panel
	SF=Adj. Shelf

PROJECT:  
KE  
318  
AN  
ARCH  
ER  
COM  
J. M. DON

**KITCHEN 116**  
**REFRIGERATOR/FREEZER WALL**

DWN BY: MJ SCALE: AS NOTED DWG.NO.: S4.0  
DATE: 08/30/24





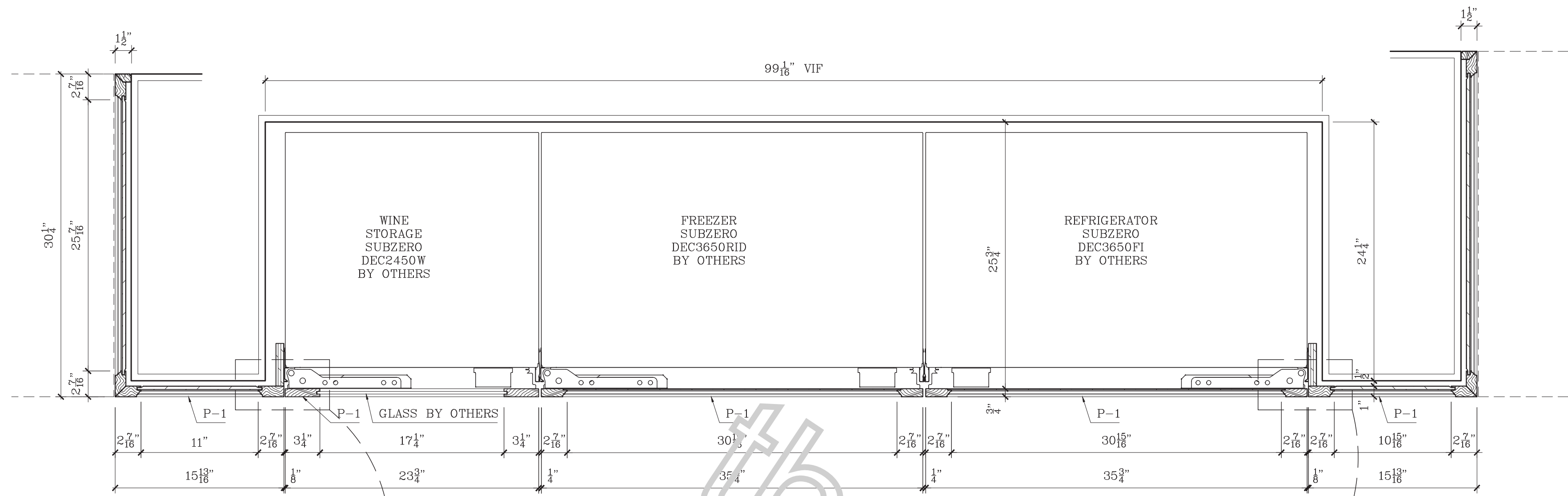

3 PLAN SECTION  
SCALE: 1-1/2"=1'-0"

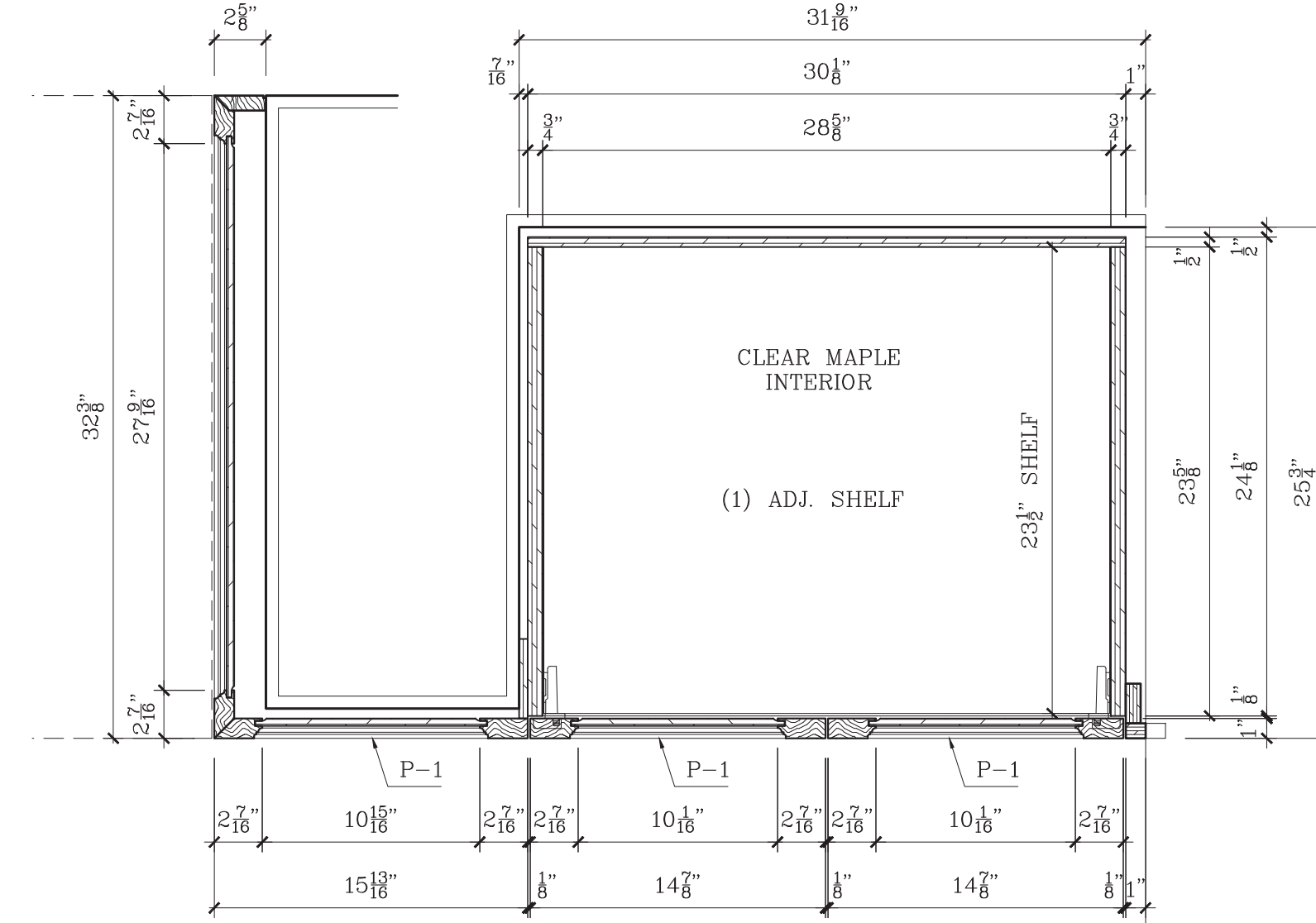
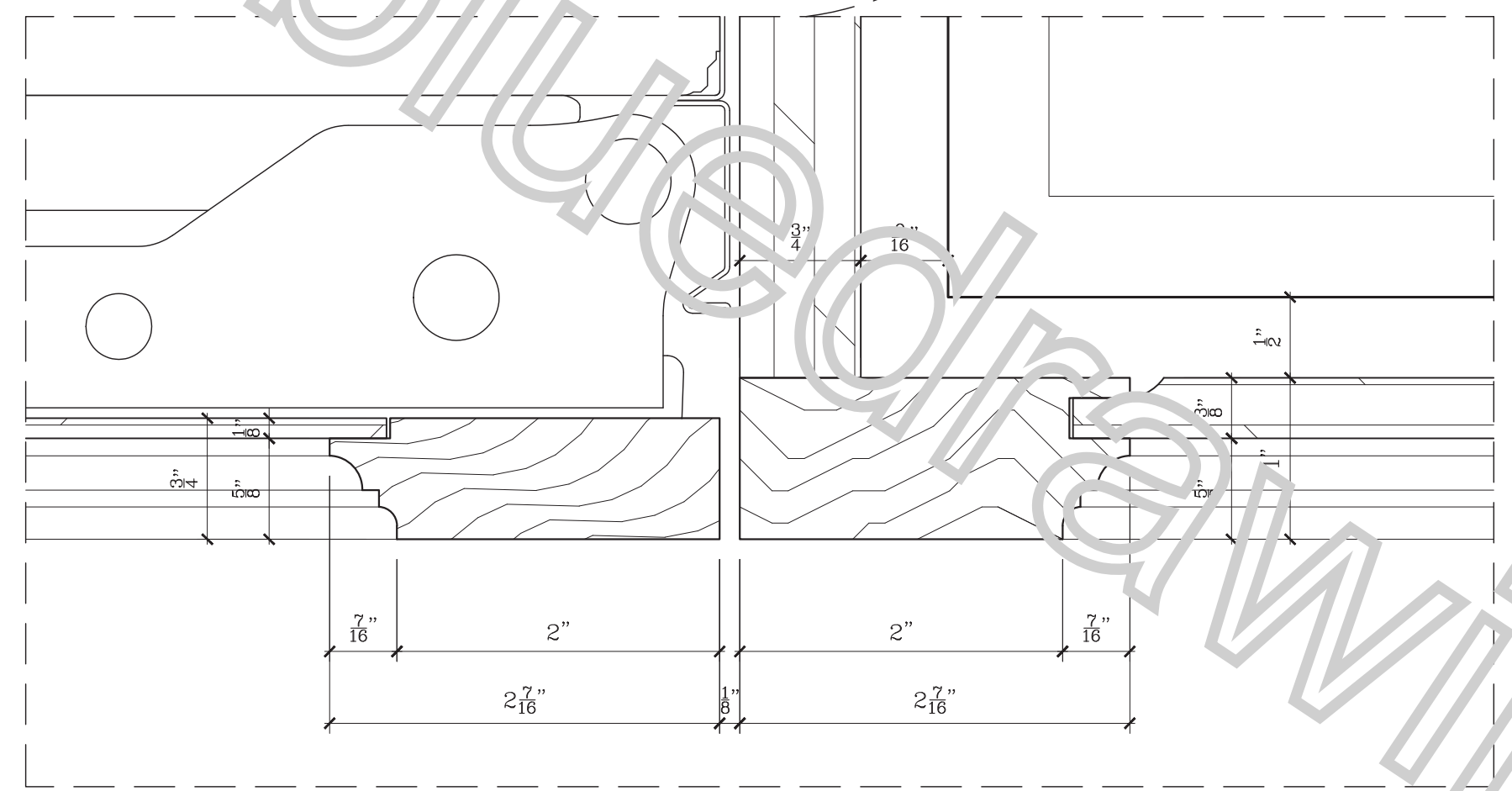
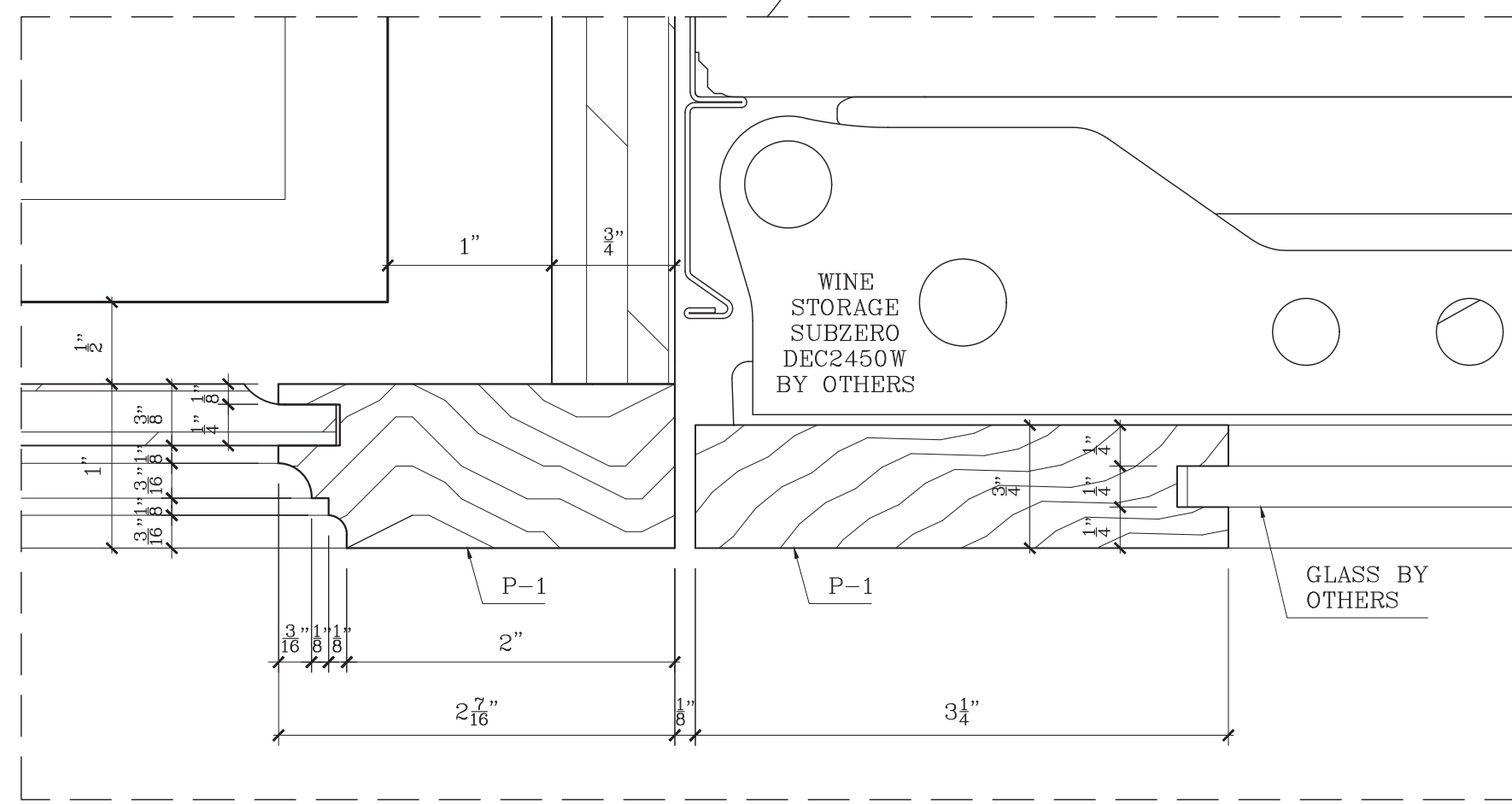

4 PLAN SECTION  
SCALE: 1-1/2"=1'-0"

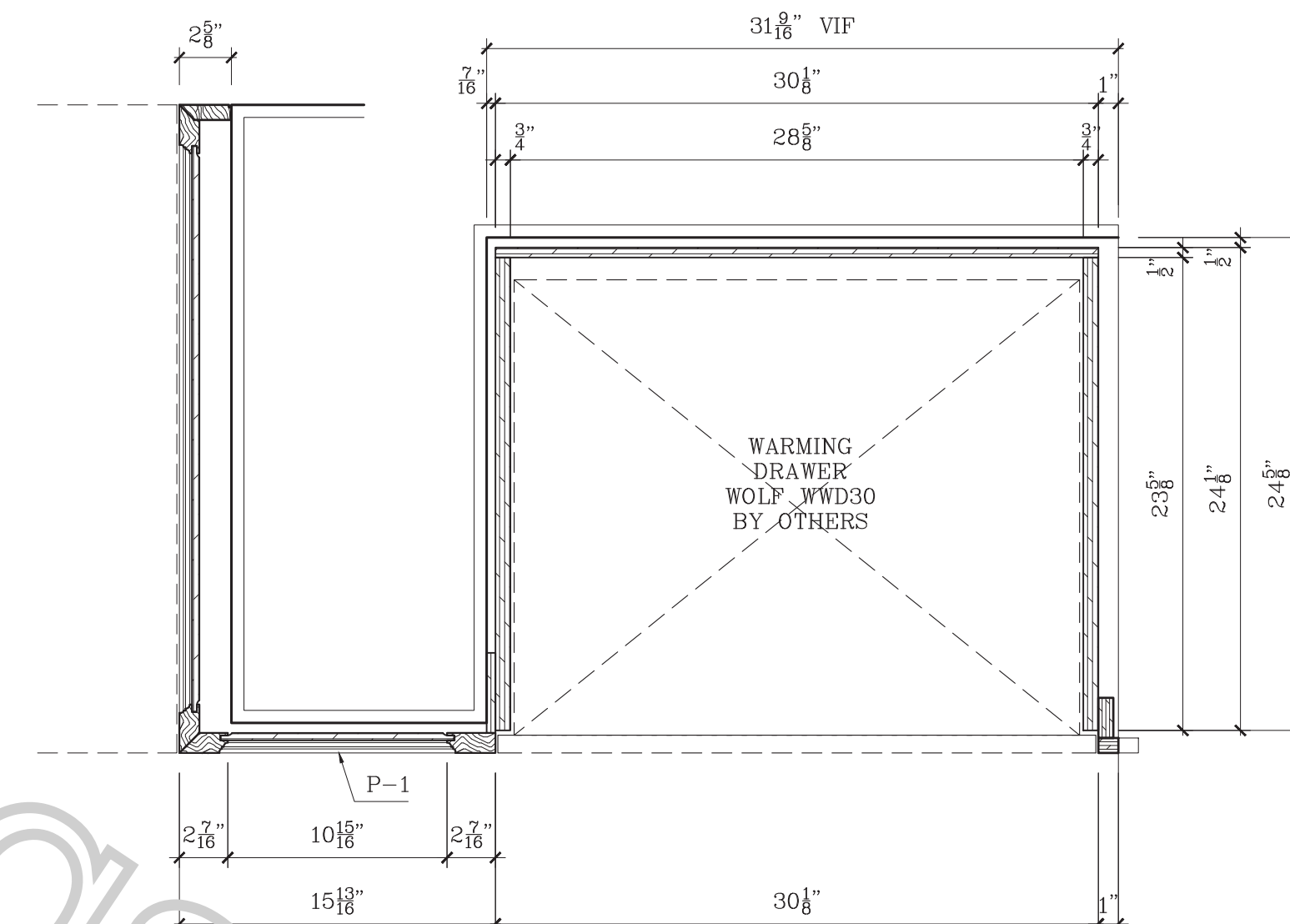

5 PLAN SECTION  
SCALE: 1-1/2"=1'-0"

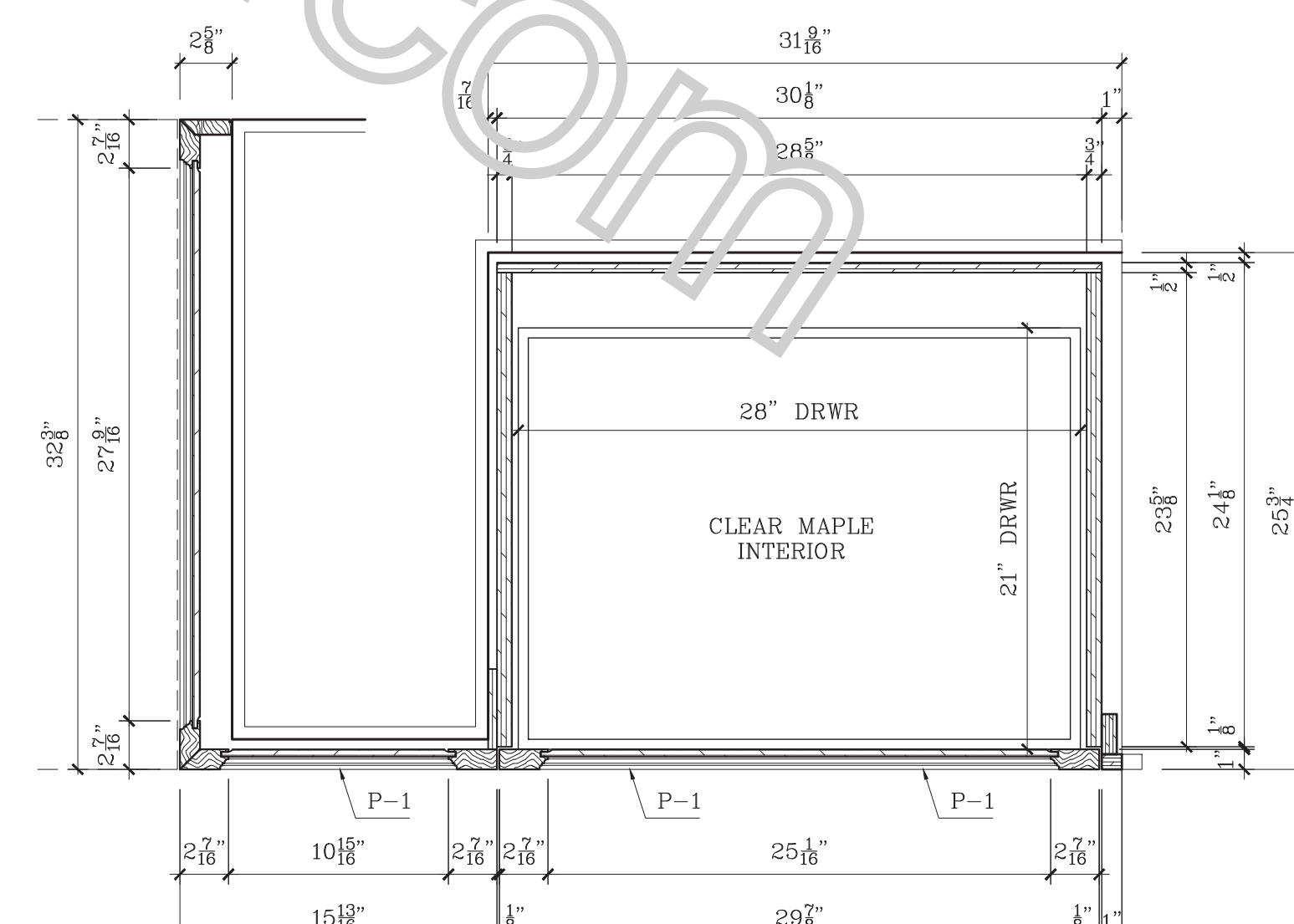

5A PLAN SECTION  
SCALE: 1-1/2"=1'-0"

SPECIFICATIONS

**FINISHES**

P-1	RIFT SAWN WHITE OAK, STAINED & CLEAR
CM	CLEAR MAPLE INTERIOR
GL-1	GLASS, TBD

**HARDWARE**

H-1	EURO HINGE - BLUM, SOFT CLOSE, CONCEALED
H-2	SHELF PINS
H-3	PULL, TBD
H-4	A&M C-FLAT 18
H-5	Z-CLIPS
H-6	DRAWER SLIDE, SOFT CLOSE - BLUM, MOVENTO

**APPLIANCE & EXCLUSIONS**

COUNTERTOPS & BACKSPLASH BY OTHERS
APPLIANCES BY OTHERS

APPROVED/NO CHANGES  
APPROVED/AS NOTED  
REVISE AS NOTED/RESUBMIT

SIGNATURE \_\_\_\_\_ DATE \_\_\_\_\_

**LEGEND**

	-ELEVATION No		-CABINET No		-FIELD JOINT
	-DRAWING No		-NOTES		-SHOP JOINT
	-ITEM No		-SPECIFICATIONS		

**REVISIONS**

Nr	DATE	DESCRIPTION	BY	OBS.

**ABBREVIATIONS**

AFF=Above Fin Floor	FE=Finished End
BSE=Base	FF=Face Frame
BCK=Back	FO=Finished Opening
CAB=Cabinet	FP=Fixed Panel
CAS=Case	ID=Inner Dimension
CL=Clear Opening	OD=Outer Dimension
CTOP=Counter Top	PNL=Panel
DB=Drawer Box	RO=Rough Opening
DF=Drawer Face	POT=Pull Out Tray
FD=Field Dimension	REM=Removable Panel
	SF=Adj. Shelf

PROJECT:

KITCHEN 116

REFRIGERATOR/FREEZER WALL

ON

DWN BY: MJ	SCALE: AS NOTED	DWG.NO.: S4.3
DATE: 08/30/24		

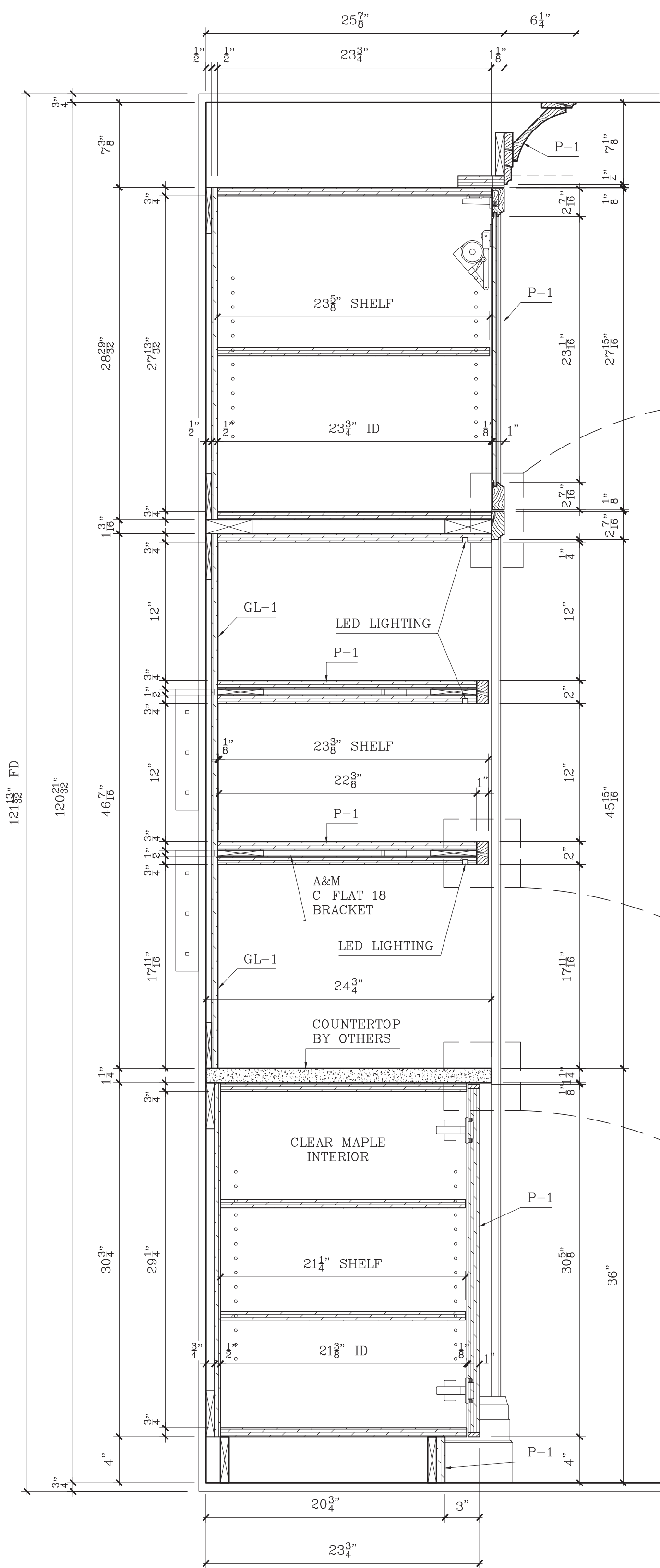

7 VERTICAL SECTION  
SCALE: 1-1/2"=1'-0"

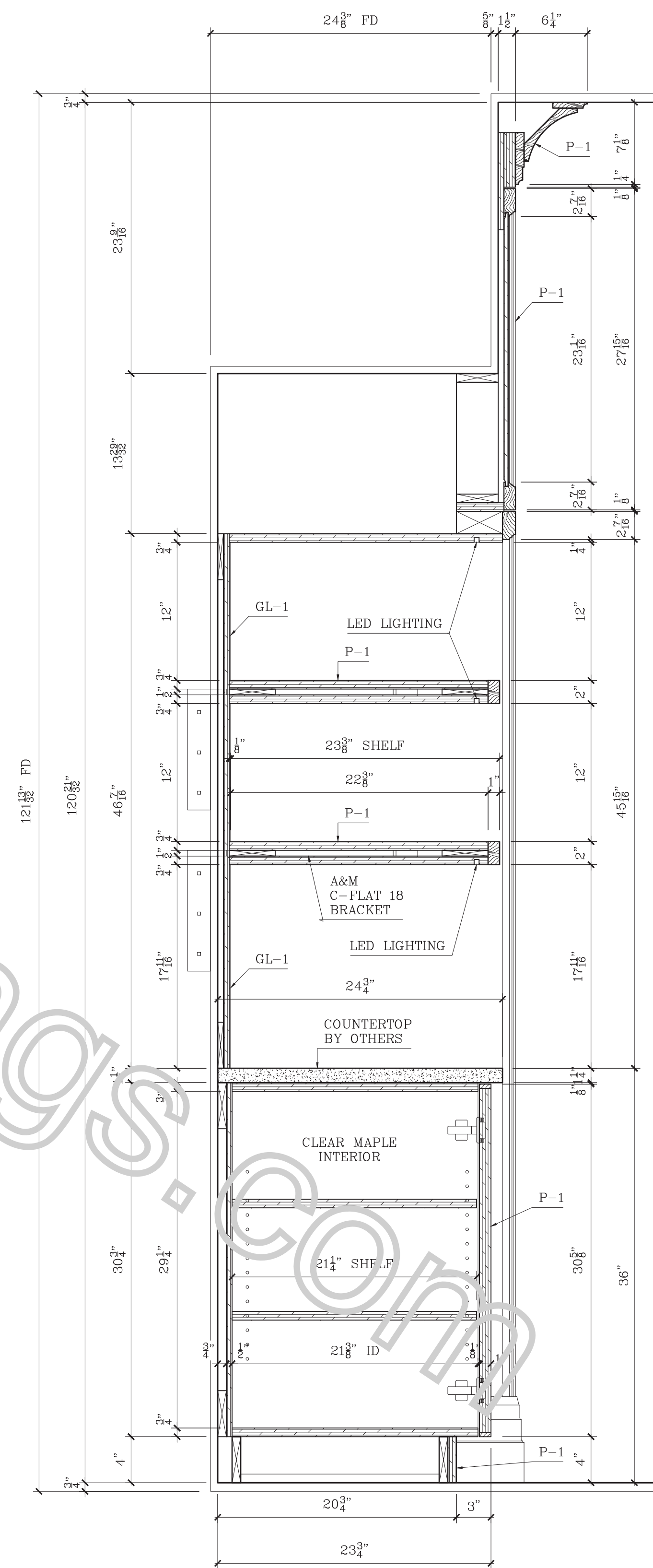
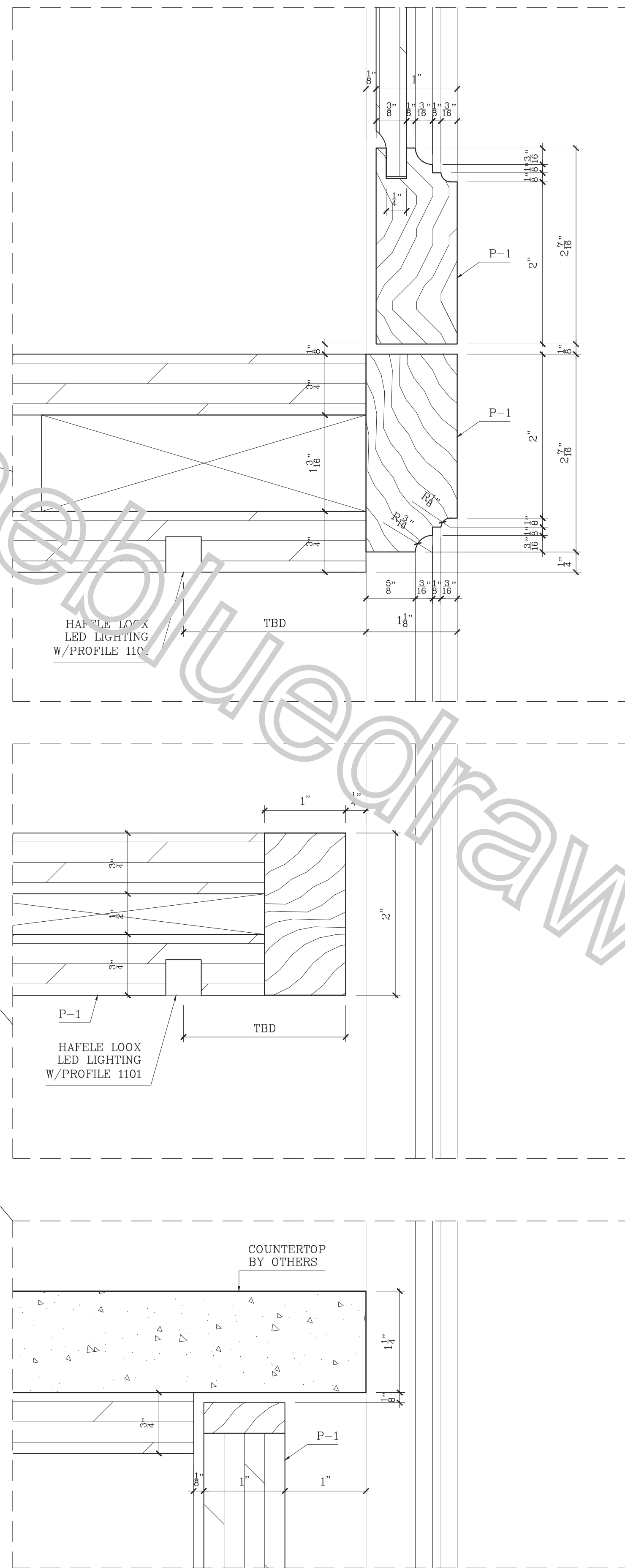

8 VERTICAL SECTION  
SCALE: 1-1/2"=1'-0"

SPECIFICATIONS

FINISHES

P-1	RIFT SAWN WHITE OAK, STAINED & CLEAR
CM	CLEAR MAPLE INTERIOR
GL-1	GLASS, TBD

HARDWARE

H-1	EURO HINGE - BLUM, SOFT CLOSE, CONCEALED
H-2	SHELF PINS
H-3	PULL, TBD
H-4	A&M C-FLAT 18
H-5	Z-CLIPS
H-6	DRAWER SLIDE, SOFT CLOSE - BLUM, MOVENTO

APPLIANCE & EXCLUSIONS

COUNTERTOPS & BACKSPLASH BY OTHERS  
APPLIANCES BY OTHERS

APPROVED/NO CHANGES  
APPROVED/AS NOTED  
REVISE AS NOTED/RESUBMIT

SIGNATURE \_\_\_\_\_ DATE \_\_\_\_\_

LEGEND

	-ELEVATION No		-CABINET No		-FIELD JOINT
	-DRAWING No		-NOTES		-SHOP JOINT
	-ITEM No		-SPECIFICATIONS		

REVISIONS

Nr	DATE	DESCRIPTION	BY	OBS.

ABBREVIATIONS

AFF=Above Fin Floor	FE=Finished End
BSE=Base	FF=Face Frame
BCK=Back	FO=Finished Opening
CAB=Cabinet	FP=Fixed Panel
CAS=Casing	ID=Inner Dimension
CL=Clear Opening	OD=Outer Dimension
CTOP=Counter Top	PNL=Panel
DB=Drawer Box	RO=Rough Opening
DF=Drawer Face	POT=Pull Out Tray
FD=Field Dimension	REM=Removable Panel
	SHE=Adj. Shelf

PROJECT:

KE  
318  
AN  
ARCH  
ER  
COM  
J. M. DON

KITCHEN 116  
REFRIGERATOR/FREEZER WALL

DWN BY: MJ	SCALE: AS NOTED	DWG.NO.: S4.4
DATE: 08/30/24		

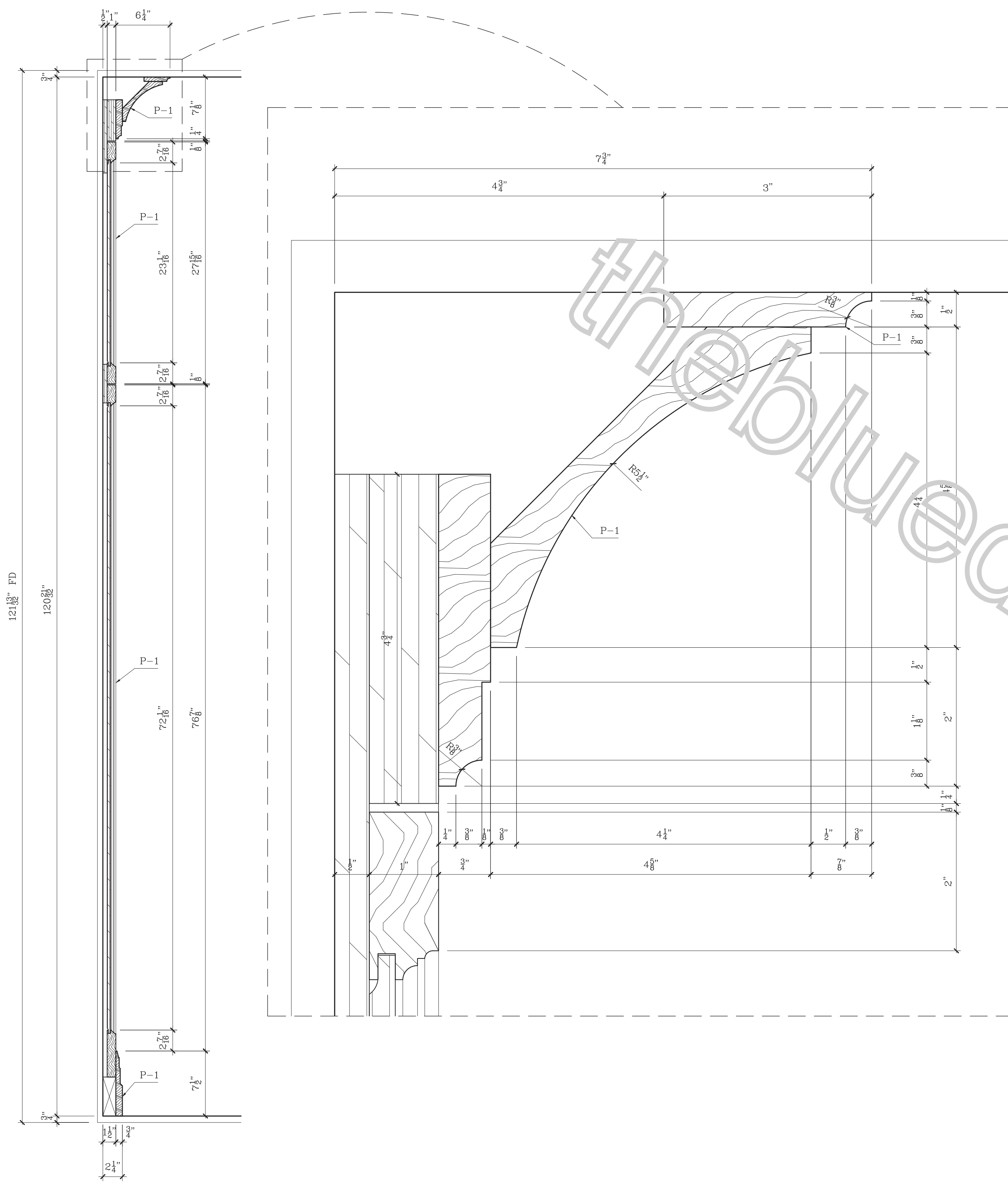

9 VERTICAL SECTION  
SCALE: 1-1/2"=1'-0"

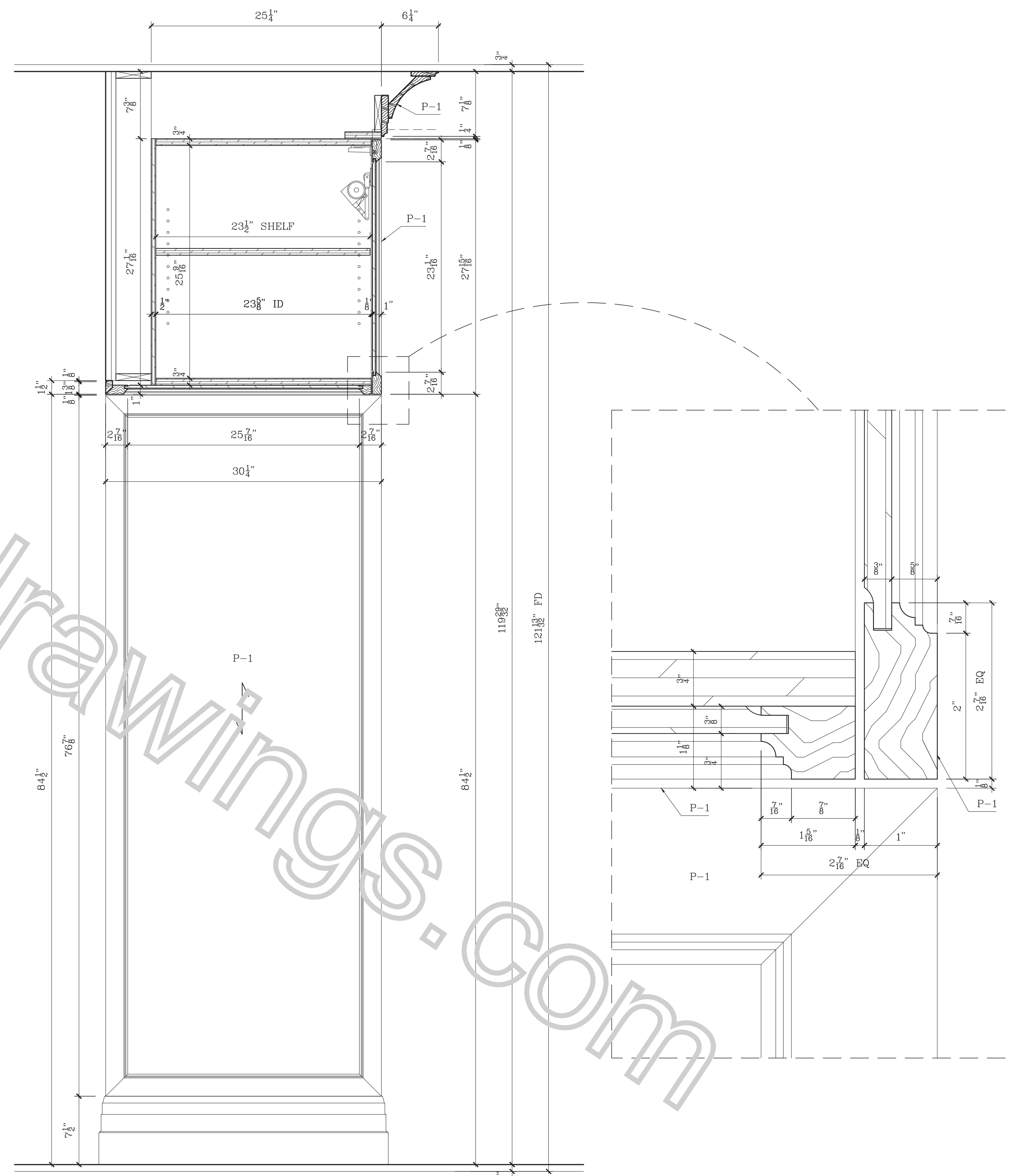

10 VERTICAL SECTION  
SCALE: 1-1/2"=1'-0"

SPECIFICATIONS

FINISHES	
P-1	RIFT SAWN WHITE OAK, STAINED & CLEAR
CM	CLEAR MAPLE INTERIOR
GL-1	GLASS, TBD

HARDWARE	
H-1	EURO HINGE - BLUM, SOFT CLOSE, CONCEALED
H-2	SHELF PINS
H-3	PULL, TBD
H-4	A&M C-PLAT 18
H-5	Z-CLIPS
H-6	DRAWER SLIDE, SOFT CLOSE - BLUM, MOVENTO

APPLIANCE & EXCLUSIONS	
COUNTERTOPS & BACKSPLASH BY OTHERS	
APPLIANCES BY OTHERS	

APPROVED/NO CHANGES  
APPROVED/AS NOTED  
REVISE AS NOTED/RESUBMIT

SIGNATURE \_\_\_\_\_ DATE \_\_\_\_\_

LEGEND			
	-ELEVATION No	#	-CABINET No
	-DRAWING No		-FIELD JOINT
	-ITEM No		-SHOP JOINT
	-DRAWING No		-NOTES
			-SPECIFICATIONS

REVISIONS				
Nr	DATE	DESCRIPTION	BY	OBS.

ABBREVIATIONS	
AFF=Above Fin Floor	FE=Finished End
BSE=Base	FF=Face Frame
BCK=Back	FO=Finished Opening
CAB=Cabinet	FP=Fixed Panel
CAS=Case	ID=Inner Dimension
CL=Clear Opening	OD=Outer Dimension
CTOP=Counter Top	PNL=Panel
DB=Drawer Box	RO=Rough Opening
DF=Drawer Face	POT=Pull Out Tray
FD=Field Dimension	REM=Removable Panel
	SF=Adj. Shelf

PROJECT:  
K  
3  
A  
AR  
E  
C  
J  
ION

KITCHEN 116  
REFRIGERATOR/FREEZER WALL

DWN BY: MJ	SCALE: AS NOTED	DWG.NO.: S4.5
DATE: 08/30/24		

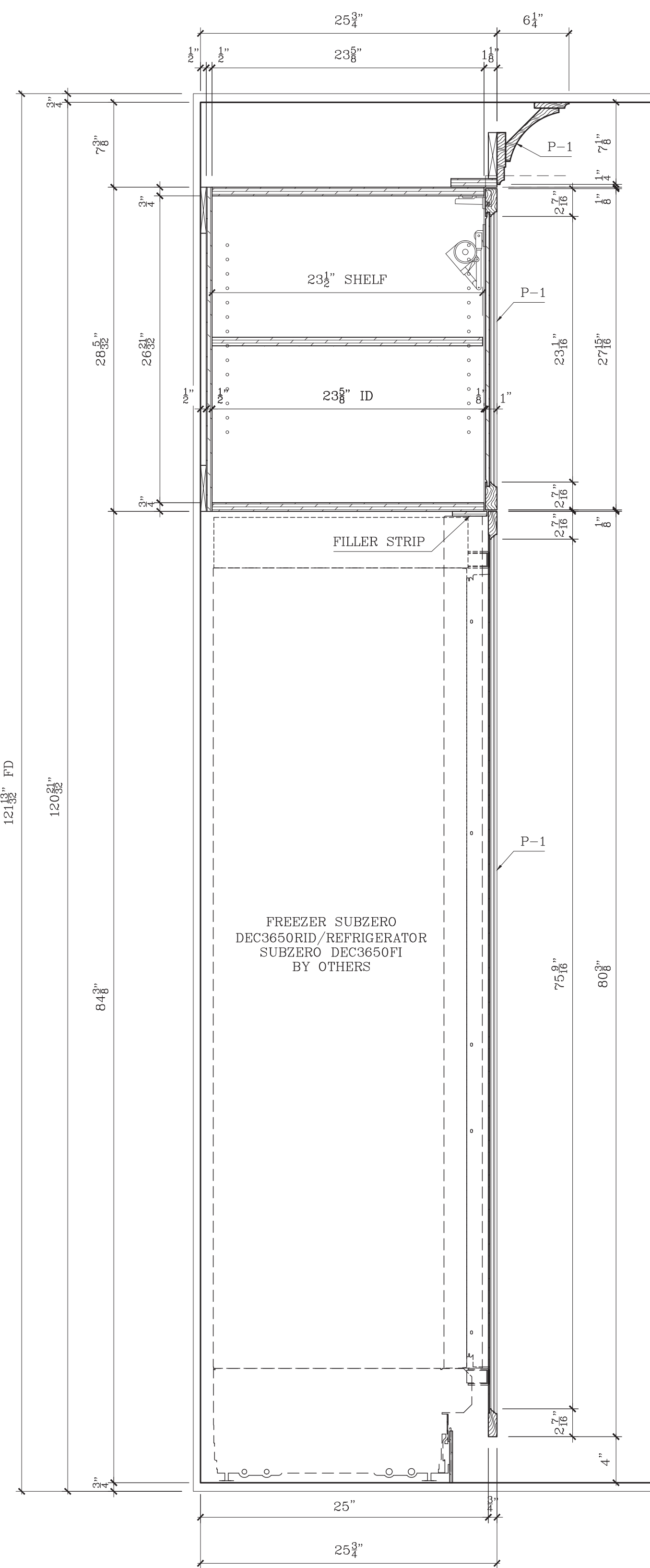

11 VERTICAL SECTION  
SCALE: 1-1/2"=1'-0"

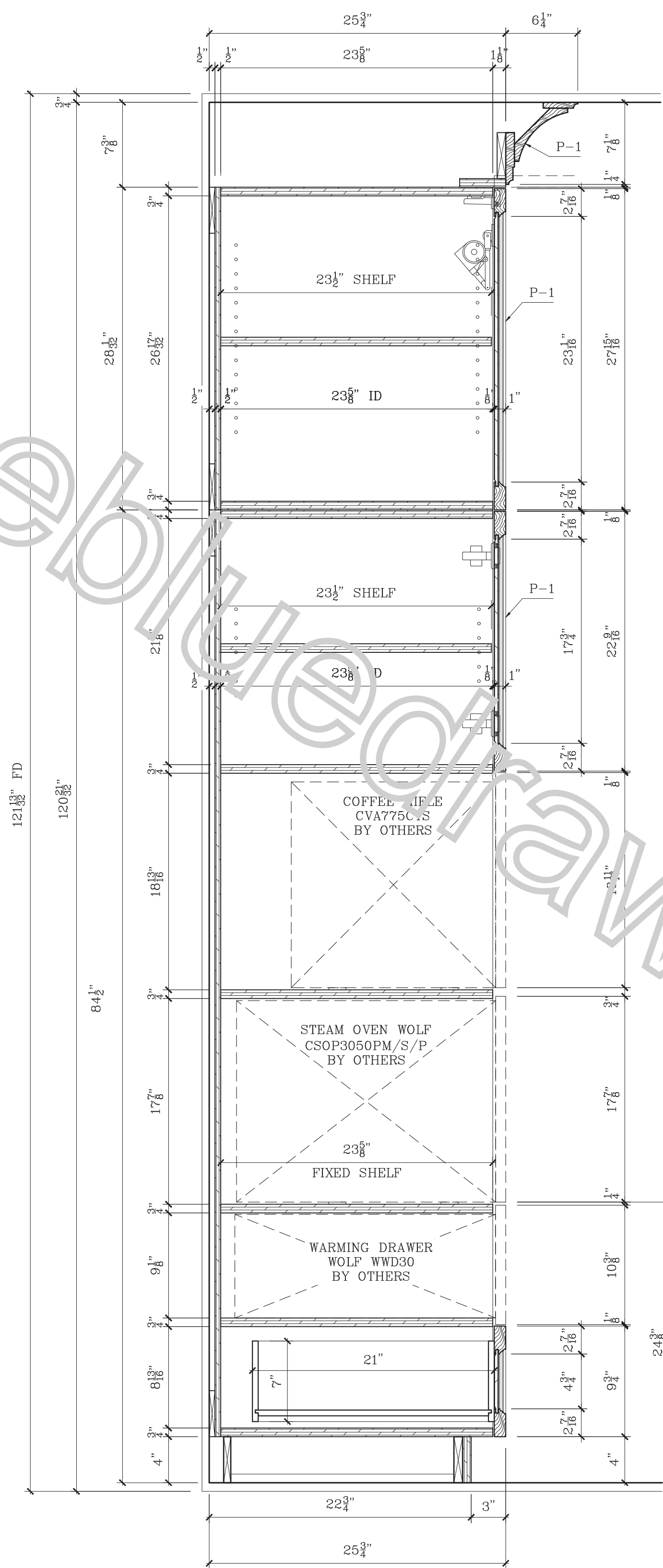

12 VERTICAL SECTION  
SCALE: 1-1/2"=1'-0"

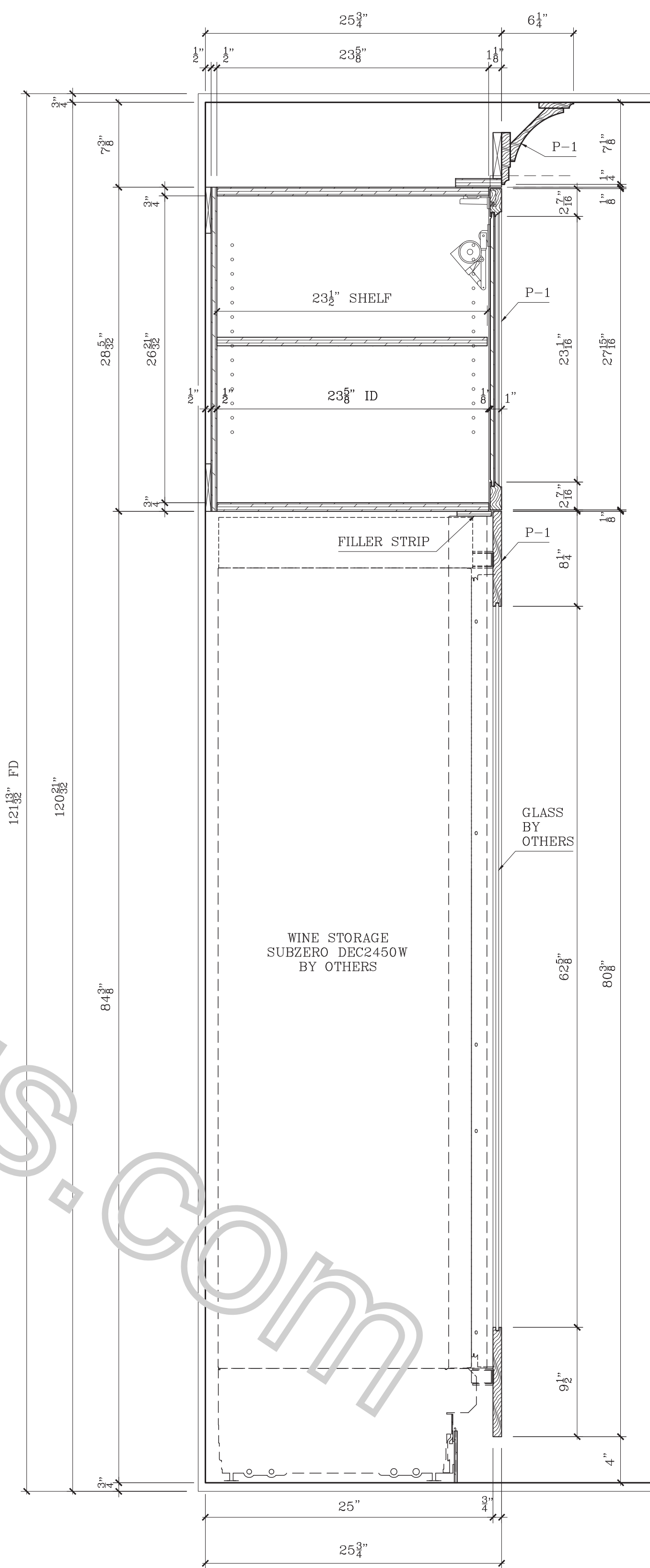

13 VERTICAL SECTION  
SCALE: 1-1/2"=1'-0"

SPECIFICATIONS

FINISHES

P-1	RIFT SAWN WHITE OAK, STAINED & CLEAR
CM	CLEAR MAPLE INTERIOR
GL-1	GLASS, TBD

HARDWARE

H-1	EURO HINGE - BLUM, SOFT CLOSE, CONCEALED
H-2	SHELF PINS
H-3	PULL, TBD
H-4	A&M C-FLAT 18
H-5	Z-CLIPS
H-6	DRAWER SLIDE, SOFT CLOSE - BLUM, MOVENTO

APPLIANCE & EXCLUSIONS

COUNTERTOPS & BACKSPLASH BY OTHERS  
APPLIANCES BY OTHERS

APPROVED/NO CHANGES  
APPROVED/AS NOTED  
REVISE AS NOTED/RESUBMIT

SIGNATURE \_\_\_\_\_ DATE \_\_\_\_\_

LEGEND

	-ELEVATION No	#	-CABINET No		-FIELD JOINT
	-DRAWING No				-SHOP JOINT
	-ITEM No		-NOTES		
	-DRAWING No		-SPECIFICATIONS		

REVISIONS

Nr	DATE	DESCRIPTION	BY	OBS.

ABBREVIATIONS

AFF=Above Fin Floor	FE=Finished End
BSE=Base	FF=Face Frame
BCK=Back	FO=Finished Opening
CAB=Cabinet	FP=Fixed Panel
CAS=Case	ID=Inner Dimension
CL=Clear Opening	OD=Outer Dimension
CTOP=Counter Top	PNL=Panel
DB=Drawer Box	RO=Rough Opening
DF=Drawer Face	POT=Pull Out Tray
FD=Field Dimension	REM=Removable Panel
	SHE=Adj. Shelf

PROJECT:

K  
3  
A  
AF  
E  
c  
J  
ION

KITCHEN 116  
REFRIGERATOR/FREEZER WALL

DWN BY: MJ	SCALE: AS NOTED	DWG.NO.: S4.6
DATE: 08/30/24		

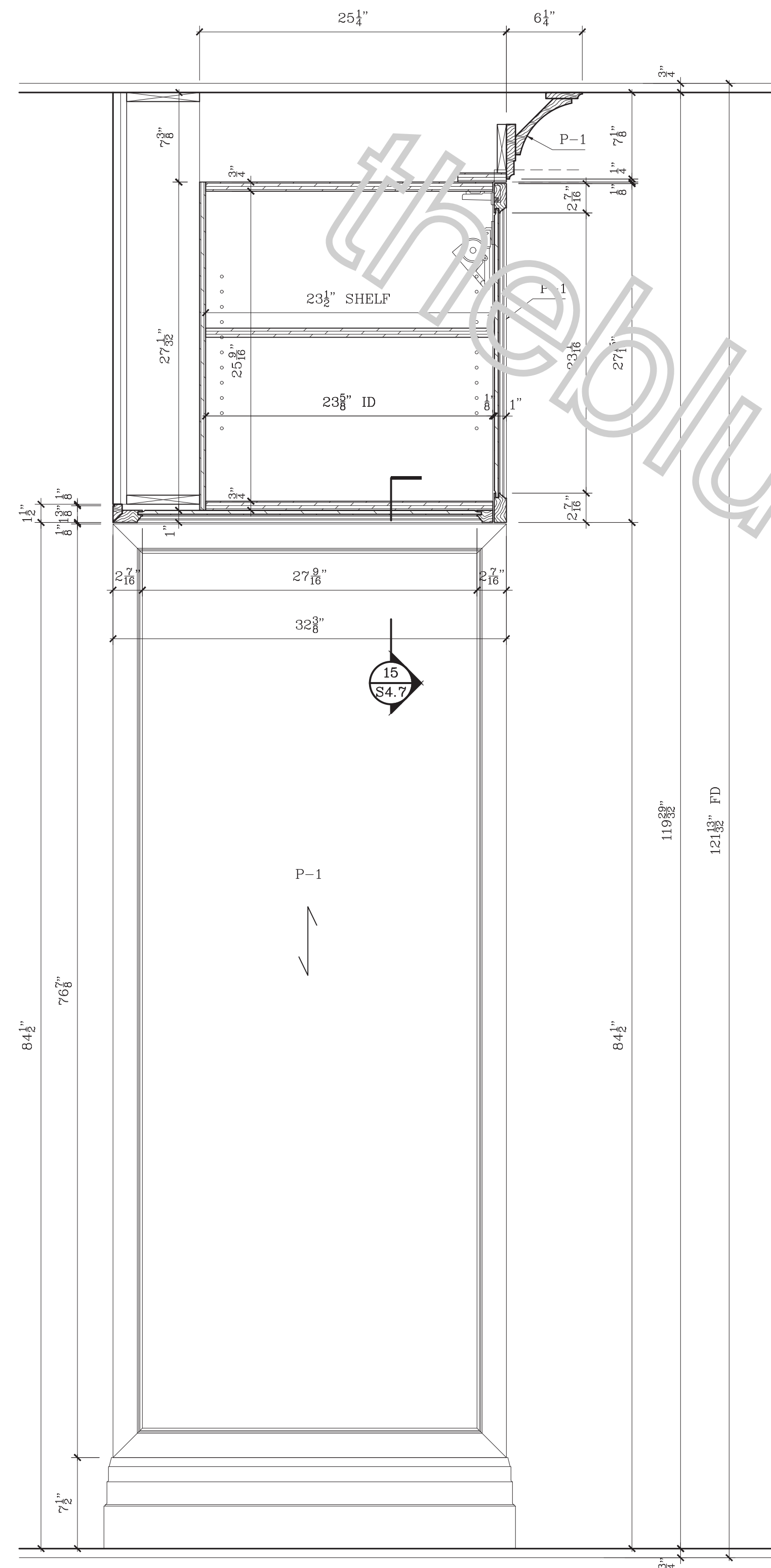

14 VERTICAL SECTION  
SCALE: 1-1/2"=1'-0"

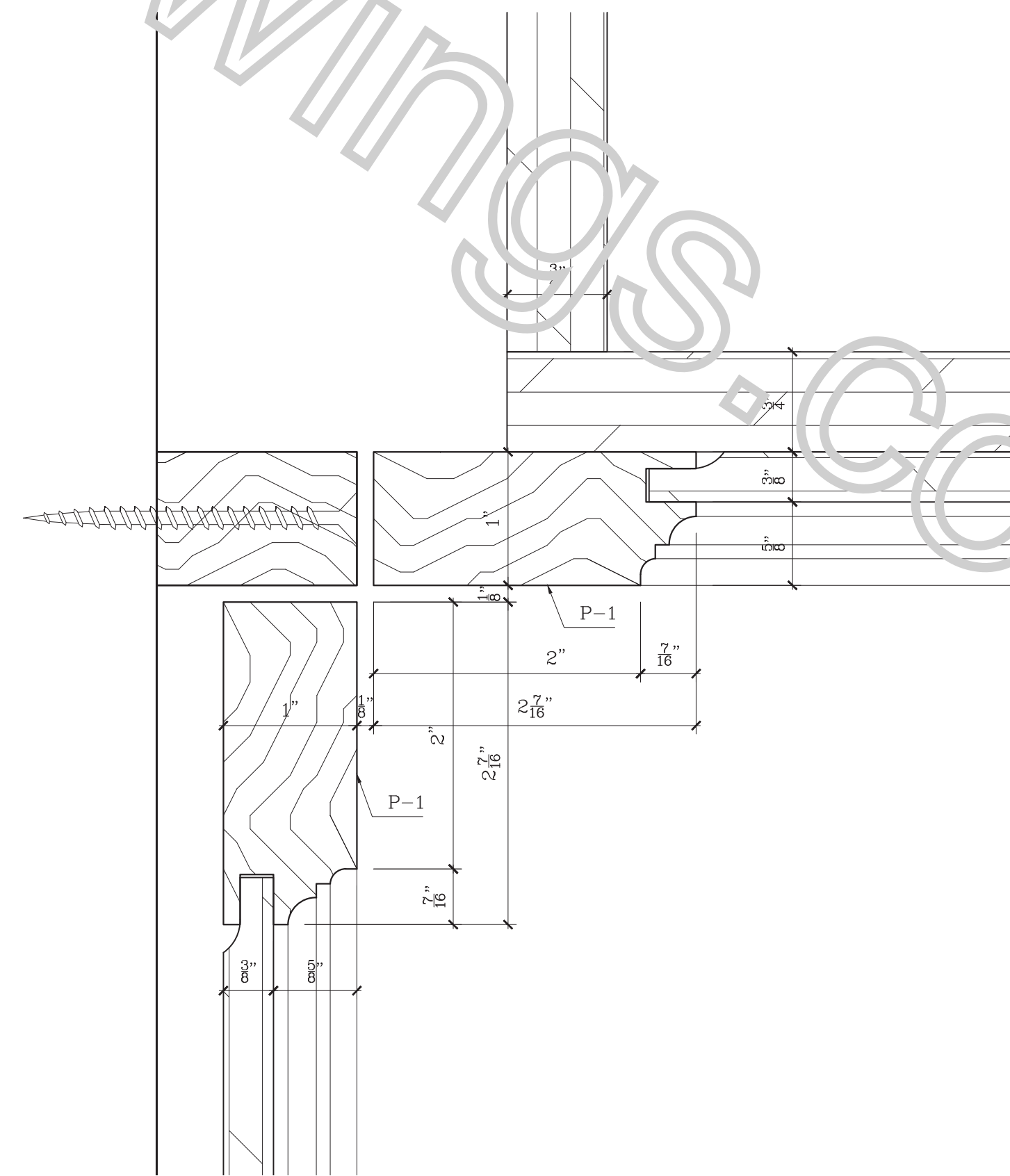

15 VERTICAL SECTION  
SCALE: 1-0"=1'-0"

**SPECIFICATIONS**

**FINISHES**

<b>P-1</b>	RIFT SAWN WHITE OAK, STAINED & CLEAR
<b>CM</b>	CLEAR MAPLE INTERIOR
<b>GL-1</b>	GLASS, TBD

**HARDWARE**

<b>H-1</b>	EURO HINGE - BLUM, SOFT CLOSE, CONCEALED
<b>H-2</b>	SHELF PINS
<b>H-3</b>	PULL, TBD
<b>H-4</b>	A&M C-PLAT 18
<b>H-5</b>	Z-CLIPS
<b>H-6</b>	DRAWER SLIDE, SOFT CLOSE - BLUM, MOVENTO

**APPLIANCE & EXCLUSIONS**

COUNTERTOPS & BACKSPLASH BY OTHERS  
APPLIANCES BY OTHERS

APPROVED/NO CHANGES  
APPROVED/AS NOTED  
REVISE AS NOTED/RESUBMIT

SIGNATURE \_\_\_\_\_ DATE \_\_\_\_\_

**LEGEND**

	-ELEVATION No		-CABINET No		-FIELD JOINT
	-DRAWING No		-NOTES		-SHOP JOINT
	-ITEM No		-SPECIFICATIONS		

**REVISIONS**

Nr	DATE	DESCRIPTION	BY	OBS.

**ABBREVIATIONS**

AFF=Above Fin Floor	FE=Finished End
BSE=Base	FF=Face Frame
BCK=Back	FO=Finished Opening
CAB=Cabinet	FP=Fixed Panel
CAS=Case	ID=Inner Dimension
CL=Clear Opening	OD=Outer Dimension
CTOP=Counter Top	PNL=Panel
DB=Drawer Box	RO=Rough Opening
DF=Drawer Face	POT=Pull Out Tray
FD=Field Dimension	REM=Removable Panel
	SIF=Adj. Shelf

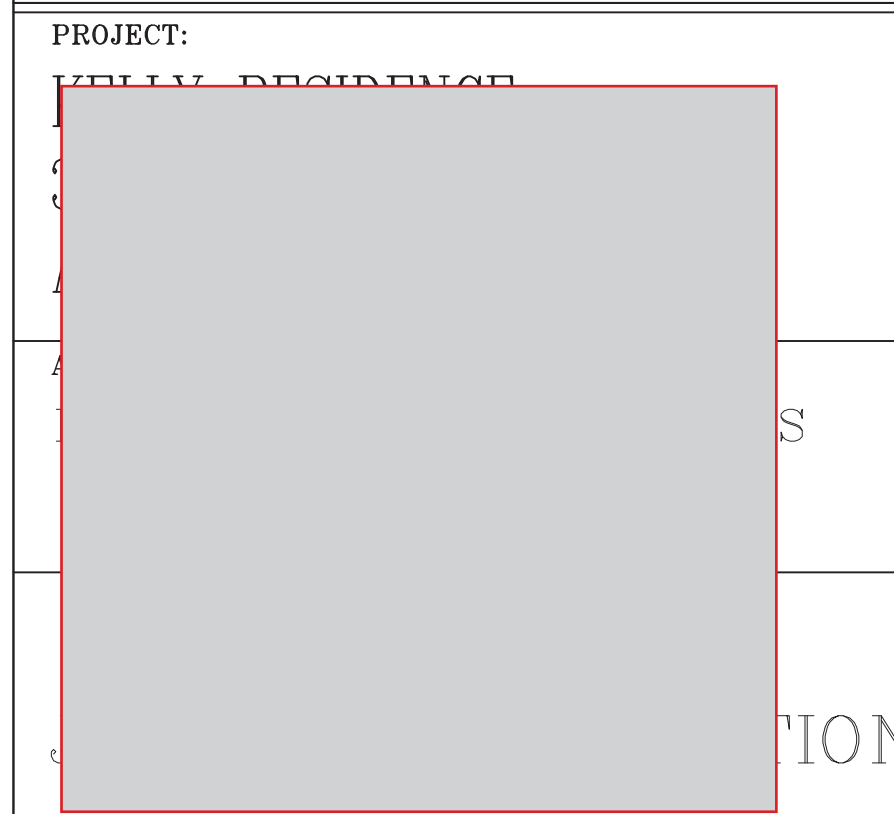

KITCHEN 116  
REFRIGERATOR/FREEZER WALL

DWN BY: MJ	SCALE: AS NOTED	DWG.NO.: S4.7
DATE: 08/30/24		